

1. May 10, 2021 Agenda/CARS

Documents:

MAY 10, 2021 ITEM 1 AGENDA.PDF
MAY 10, 2021 ITEM 3 EMPOWERMENT CTR.PDF
MAY 10, 2021 ITEM 4 JUNETEENTH.PDF
MAY 10, 2021 ITEM 5 ORD 1177.PDF
MAY 10, 2021 ITEM 6 ARCHITECT BEASLEY.PDF
MAY 10, 2021 ITEM 7 RESOLUTION 21-10.PDF
MAY 10, 2021 ITEM 8 SEAWALL.PDF
MAY 10, 2021 ITEM 9 RESOLUTION 21-09.PDF

**City of Cambridge
City Commission Meeting
Monday, May 10, 2021
Commission Chambers - 305 Gay Street
Cambridge, MD 21613**

Notice to Citizens: The City Commissioners are conducting the City business by way of a conference call because of the Corona Virus threat. Citizens may observe the meeting by going on-line to TownHallStreams.com. Citizens may call in their public comments by calling the mayor during the meeting at 410 228-5808 or citizens may participate in the meeting by logging into the meeting by calling 408-418-9388 and entering the meeting number and password: Meeting Number 132 958 6308; Password 5808.

6:00 pm Mayor to Convene Commission in Regular Session

Agenda

1. Commission to approve or amend agenda as presented.

Requests from the Public

Sar Rich, CEO Choptank Community Health System
Unity Solar Presentation
Veterans Flag Program - Rotary

Consent Calendar

2. April 26, 2021 Meeting Minutes
3. Joyce Green of the Empowerment Center is requesting to have use of the corner of Cedar and Race Streets for her Daily Physical Fitness Fun Sessions for the Summer Program from July 5, 2021 to August 20, 2021.
4. Alpha Genesis is requesting to have the "Juneteenth Celebration"/BLM Mural "touch-up" on the 400 block of Race street/Cannery Way on Saturday June 19, 2021 from 10am-10pm.

Ordinances for Introduction and First Reading

Ordinances for Second Reading, Public Hearing, and Adoption

5. Ordinance No. 1177 - An Ordinance Of The Commissioners Of Cambridge, Maryland To Establish The Annual Tax Levy For Real And Personal Property For Fiscal Year 2022 Beginning July 1, 2021 And Ending June 30, 2022.
 - A. Second Reading
 - B. Public Hearing
 - C. Commission decides on the Ordinance

Old Business

6. Authorization for City Manager to have Architect began work for Beasley project
7. Resolution Beasley Project Pine and Wells Street

New Business

8. Award of Contract for the Oakley Street Seawall Replacement
9. Resolution for TAG Grant \$35,000

Meetings

May 13, 2021 at 6pm, Budget Work Session at Commission Chamber, 305 Gay Street

May 17, 2021 at 6pm, Budget Work Session at Commission Chamber, 305 Gay Street

Notices

Mayor and Council

Public Comment

Mayor's Comments

Adjourn

City Council meetings are conducted in open session unless otherwise indicated. Pursuant to the Maryland Open Meetings Act, all or a portion of the Council meeting may be held in closed session by vote of the Council. Please note that the order of agenda items is subject to change and that meetings are subject to audio and video recording.

Pine Street Committee, Inc
615 - B Pine Street
P.O. Box 494
Cambridge, Maryland 21613



Phone: 410-901-1397
Email: empowermentcenter@ymail.com
www.cambridgeempowermentcenter.com

Agenda Item No. 3

Date May 10, 2021

To: Cambridge City Council

We greet you with peace and love.

The Pine Street Committee is in process of planning for their upcoming Summer Program.

Due to our current restrictions, we will have to make some changes to make our program and activities safer for everyone.

The program will begin July 5, 2021, and end August 20, 2021.

We are asking for permission to use the open field on the corner of Cedar and Race Street.

It will be used for our new **Daily Physical Fitness Fun Sessions. (2-3 Hours)**

Our prayer is that the Council will approve this request, and if you need more information, please feel free to contact me.

Thank you in advance,

Joyce Green

Vice President/ Summer Program Coordinator

Pine Street Committee



APPLICATION FOR A SPECIAL EVENT PERMIT

Date of Application: May 7, 2021

Event Title or Type: Suneteeth Celebration/BLM Mural Touch

Location of Event: 400 Block of Race St./Cannery Way/Take ^{up} my Hand Mural

Date(s) of Event: Saturday June 19, 2021

Hours of Event (Actual): 10 am - 10 pm

Name of Applicant: Adrian Holmes Title: President

If representing an organization or company, name(s): Alpha Genesis CDC

Signature of Applicant: Adrian R Holmes

If application is presented on or behalf of 1 or 2 businesses only, list names of business(es):

Address of Applicant: 405 Maryland Ave, Cambridge MD 21613

Telephone: 410-490-1520 Email: Adrian.Holmes@AlphaGenesisCDC.org

Expected attendance: 100

Is a street closing being requested? Yes (show on map) No

If yes, what street(s) Mur + Races to the LMS Building

If yes, indicate street closure & reopen times (include set up and breakdown time): 10 am to 10 p.m.

Is staging or a platform required? Yes (show on map) No Amplification: Yes No

If event is on private property, name of Property Owner: No

- Will trash barrels & pick-up be provided by event holder? Yes No
- Will portable toilets be provided? Yes (show on map) No
- Will tent(s) be erected? Yes (show on map) No
- Will food be prepared on the premises? Yes No
- Will food trucks be present? (list names on back of form) Yes No
- Will alcohol be served? Yes No



APPLICATION FOR A SPECIAL EVENT PERMIT

ROAD RACE, WALK-A-THON, ETC.

On Roadway? Yes No

On Sidewalk? Yes No

Will temporary signs be posted? Yes No

Specific Route:

- I attached a map showing locations of street closures, vehicles and temporary structures.
- For new events, I have attached documentation of notification of the application to all affected businesses and residents, and attest that a majority have supported and/or not objected to this event.
- I have read & agree to the City's Street Closures Policy.

FOR OFFICE USE ONLY

Conditions of Special Event Permission: _____

Police Costs: \$ _____ DPW Costs: \$ _____ Other Costs: \$ _____

TOTAL COSTS REQUIRED BY CITY COUNCIL: \$ _____

Recommendations:

Cambridge Police Department	Approval <input type="checkbox"/>	Denial <input type="checkbox"/>	_____
			Signature
Rescue Fire Department	Approval <input type="checkbox"/>	Denial <input type="checkbox"/>	_____
			Signature
Public Works Department	Approval <input type="checkbox"/>	Denial <input type="checkbox"/>	_____
			Signature

Takeout

Harriet Tubman Museum
and Educational Center



Alley 26



Black Water
Bakery + Eats
Takeout • Delivery

147 Venue



Bombay Social
Takeout • Delivery



Rig Holdings



Muir St



ORDINANCE NO. 1177**FISCAL YEAR 2022 TAX RATES****AN ORDINANCE OF THE COMMISSIONERS OF CAMBRIDGE, MARYLAND TO ESTABLISH THE ANNUAL TAX LEVY FOR REAL AND PERSONAL PROPERTY FOR FISCAL YEAR 2022 BEGINNING JULY 1, 2021 AND ENDING JUNE 30, 2022.**

WHEREAS, pursuant to Md. Code Ann., Tax-Prop. § 6-303(a)(1) and § 3-25 of the Charter of the City of Cambridge, the Commissioners of Cambridge shall annually before the last day of June set the tax rate for the next taxable year on all assessments of property subject to real and personal property tax and levy such sums as they may deem sufficient to meet and pay the running expenses of the City of Cambridge (the "City"); and

WHEREAS, on May 10, 2021, the Commissioners of Cambridge held a public hearing on the proposed tax levy for real and personal property for Fiscal Year 2022 ("FY 2022"), notice of which was published in the Star Democrat, a newspaper of general circulation in the City on April 25, 2021 and in the Dorchester Star on Friday, April 30, 2021; and

WHEREAS, the Commissioners of Cambridge, after due and careful consideration, including consideration of the public comments received during the May 10, 2021 public hearing and all written comments submitted, have determined that a tax levy of \$0.8301 for each one hundred dollars (\$100.00) of assessed valuation of real property and a tax levy of \$1.69 for each one hundred dollars (\$100.00) of assessed valuation of personal property in the City for FY 2021 commencing on July 1, 2021 and ending on June 30, 2022, is fair, just, and fiscally responsible.

NOW, THEREFORE, BE IT ENACTED AND ORDAINED BY THE COMMISSIONERS OF CAMBRIDGE that the tax levy be, and the same hereby is, set at \$0.8301 for each one hundred dollars (\$100.00) of assessed valuation of real property in the City of Cambridge, and said tax rate is hereby imposed on all assessable real property for the fiscal year commencing July 1, 2021 and ending June 30, 2022.

AND BE IT FURTHER ENACTED AND ORDAINED BY THE COMMISSIONERS OF CAMBRIDGE that the tax levy be, and the same hereby is, set at \$1.69 for each one hundred dollars (\$100.00) of assessed valuation of personal property in the City of Cambridge, and said tax rate is hereby imposed on all assessable personal property for the fiscal year commencing July 1, 2021 and ending June 30, 2022.

AND BE IT FURTHER ENACTED AND ORDAINED BY THE COMMISSIONERS OF CAMBRIDGE that all fees, charges, and levies adopted by this Ordinance shall remain in effect unless changed at a future date by subsequent Ordinance by the Commissioners of Cambridge and the same shall be collected pursuant to all applicable provisions of the Charter of the City of Cambridge and State law.

AND BE IT FURTHER ENACTED AND ORDAINED BY THE COMMISSIONERS OF CAMBRIDGE that this Ordinance shall take effect July 1, 2021.

ATTEST:

THE COMMISSIONERS OF CAMBRIDGE

Patrick C. Comiskey, City Manager

Andrew Bradshaw, Mayor (SEAL)

Introduced the 26th day of April, 2021
Passed the 10th day of May, 2021
Effective the 1st day of July, 2021



Architecture + Planning + Interiors + Community Engagement

December 4, 2020

CONTRACT CHANGE ORDER

OWNER: Mr. Ed Beasley
2466 Cambridge Beltway
Cambridge, Maryland

ARCHITECT: Crosby & Associates, AIA, LLC
513 Court Lane
Cambridge, Maryland

CONTRACT FOR: Design Services
Pine Street Convenience Store

CONTRACT DATE: August 15, 2019

CHANGE ORDER NO: 01

CHANGE ORDER DATE: 12/4/2020

CROSBY & ASSOCIATES, AIA, LLC is hereby authorized to make the following changes to the contract between the parties dated August 15, 2019 and provide the following ADDITIONAL SERVICES as herein described. Additional fees shall be paid to Crosby & Associates under the terms and conditions of the current contract for these additional services as detailed below:

SCOPE OF ADDITIONAL SERVICES

The Owner has requested that the Architects provide additional Architectural and Structural Design Services to revise the previously submitted and approved Construction Documents for this project. The revisions requested are detailed in the following services description. To accomplish this goal, Crosby & Associates, AIA, LLC will provide the following ADDITIONAL SERVICES:

A. Revisions to completed Architectural Construction Documents

Crosby & Associates will revise the current Architectural Construction Documents that show the project as a two-story mixed-use commercial/residential building to show the project as a single-story commercial convenience store only. We will revise the floor plans, elevations, sections, details, schedules, and specifications to adequately show how the single-story structure would be constructed. Revised plans will be adequate to allow the Owner to submit for and receive approval of a building permit application to the City of Cambridge building permit department. Revised drawings will have the Architect's professional stamp affixed.

TOTAL FEE COST**\$23,250.00****B. Revisions to completed Structural Construction Documents**

Crosby & Associates and their structural engineering consultants will revise the current Structural Engineering Construction Documents that show the project as a two-story mixed-use

The Highcourt Center
513 Court Lane
Cambridge, MD 21613
Tel. 410.221.6508
Cell 410.476.1133



**CROSBY &
ASSOCIATES**

Architecture + Planning + Interiors + Community Engagement

commercial/residential building to show the project as a single-story commercial convenience store only. We will revise the foundation plans, framing plans and structural details to adequately show how the single-story structure would be constructed. Revised plans will be adequate to allow the Owner to submit for and receive approval of a building permit application to the City of Cambridge building permit department. Revised drawings will have the Structural Engineer's professional stamp affixed.

TOTAL FEE COST **\$2,750.00**

COST OF CHANGE ORDER SERVICES

We will provide the services listed above for a **TOTAL FIXED FEE of TWENTY-SIX THOUSAND DOLLARS AND ZERO CENTS (\$26,000.00)**. In addition to the fixed fees listed above, you will be invoiced for expenses incurred by Crosby & Associates directly connected to the completion of this Change Order. Our hourly rates and expenses are detailed on the Hourly Rates and Expense Schedule attached to our original contract. If you find this CHANGE ORDER PROPOSAL acceptable, please sign below and return one signed copy to our offices. Thank you for this opportunity to work with you.

AGREED TO BY THE CONTRACT PARTIES:

Mr. Ed Beasley

Printed Name

Date: _____

Crosby & Associates, AIA, LLC

Timothy F. Crosby

Printed Name

Date: 12/4/2020

END OF DOCUMENT

The Highcourt Center
513 Court Lane
Cambridge, MD 21613
Tel. 410.221.6508
Cell 410.476.1133

RESOLUTION NO. 21-10

A RESOLUTION OF THE COMMISSIONERS OF CAMBRIDGE, MARYLAND APPROVING AND SUPPORTING FINANCING FROM THE DEPARTMENT OF HOUSING AND COMMUNITY DEVELOPMENT (“DHDC”) NEIGHBORHOOD BUSINESSWORKS PROGRAM TO EDDIE W. BEASLEY FOR THE DEVELOPMENT AND OPERATION OF THE PINE STREET COMMUNITY MARKET.

WHEREAS, the Commissioners of Cambridge recognize that there is a significant need for reinvestment and revitalization of the communities in the City of Cambridge (the “City”); and

WHEREAS, the Commissioners of Cambridge are interested in promoting such reinvestment and revitalization of the City by encouraging the development and/or expansion of for-profit and non-profit small businesses; and

WHEREAS, Eddie W. Beasley applied to the DHDC’s Neighborhood BusinessWorks Program for financing for the development and operation of the Pine Street Community Market at 711 Pine Street, Cambridge, Maryland (the “Project”); and

WHEREAS, the Project is located in a State-approved locally designated revitalization area and complies with the City’s zoning ordinance as codified in its Unified Development Code; and

WHEREAS, the Project will provide a material benefit to the City and its residents; and

WHEREAS, the Neighborhood BusinessWorks Program regulations require that all projects receiving financing be approved and supported by the appropriate governing body of the jurisdiction in which the project is located; and

WHEREAS, the Commissioners of Cambridge are desirous of approving and supporting the Project and DHCD’s financing thereof through the Neighborhood BusinessWorks Program.

NOW, THEREFORE, BE IT RESOLVED BY THE COMMISSIONERS OF CAMBRIDGE that the Commissioners of Cambridge hereby approve and support the Project and DHCD’s financing thereof through the Neighborhood BusinessWorks Program to Eddie W. Beasley.

AND BE IT FURTHER RESOLVED THAT, upon adoption, copies of this Resolution shall be sent to Michael Haloskey, Director, Neighborhood BusinessWorks Program, at the Maryland Department of Housing and Community Development, 100 Community Place, Crownsville, Maryland 21032. DHCD.

AND BE IT FURTHER RESOLVED THAT, in executing this Resolution, the Mayor hereby certifies that this Resolution is true and correct and duly adopted by the Commissioners of Cambridge.

ATTEST:

THE COMMISSIONERS OF CAMBRIDGE

Patrick C. Comiskey
City Manager

BY: _____
Andrew Bradshaw
Mayor

Adopted the 10th day of May, 2021
Effective the 10th day of May, 2021

Council Agenda Report

Date: May 12, 2021

Prepared by: George W. Hyde, PE, City Engineer

Submitted by: Patrick Comiskey, City Manager

SUBJECT: Award of Contract for the Oakley Street Seawall Replacement

Recommendation: That Council award the contract for the Oakley Street Seawall Replacement to David A. Bramble, Inc. in the amount of \$243,693 plus a contingency for unforeseen issues, not to exceed 5%.

Discussion:

In 2017, the City received a \$35,000 grant from the DNR Chesapeake & Coastal Service to perform an engineering study of the concrete seawalls at the ends of Oakley St., Willis St., West End Ave. and Choptank Ave. The study looked at existing conditions and included preliminary designs for replacement. It also prioritized the schedule for replacement based on the condition of each seawall. The Oakley St. seawall was found to be in the worst shape and had the highest priority for replacement.

In April 2020, the City was awarded a grant from the Maryland Department of the Environment to go toward the City's seawall replacement project. The grant will fund up to \$368,000 but requires a 25% match.

DPW prepared bid documents, acquired permits, advertised a request for proposals and solicited bids from qualified contractors to replace the Oakley St. seawall. We received the following three (3) bids:

Company	Bid Amount
David A. Bramble, Inc.	\$243,693
Maverick Construction	\$244,900
Mar-Allen Concrete	\$328,934

The low bidder, David A. Bramble, has done previous work for the City and is well qualified to complete this project. Therefore, it is our recommendation to award the contract to them.

Fiscal Impact:

The MDE grant will be used to fund 100% of the construction contract. The required 25% match will be provided in the form of staff time for design and construction phase services along with the prior engineering study.

Approved by: Patrick Comiskey, City Manager

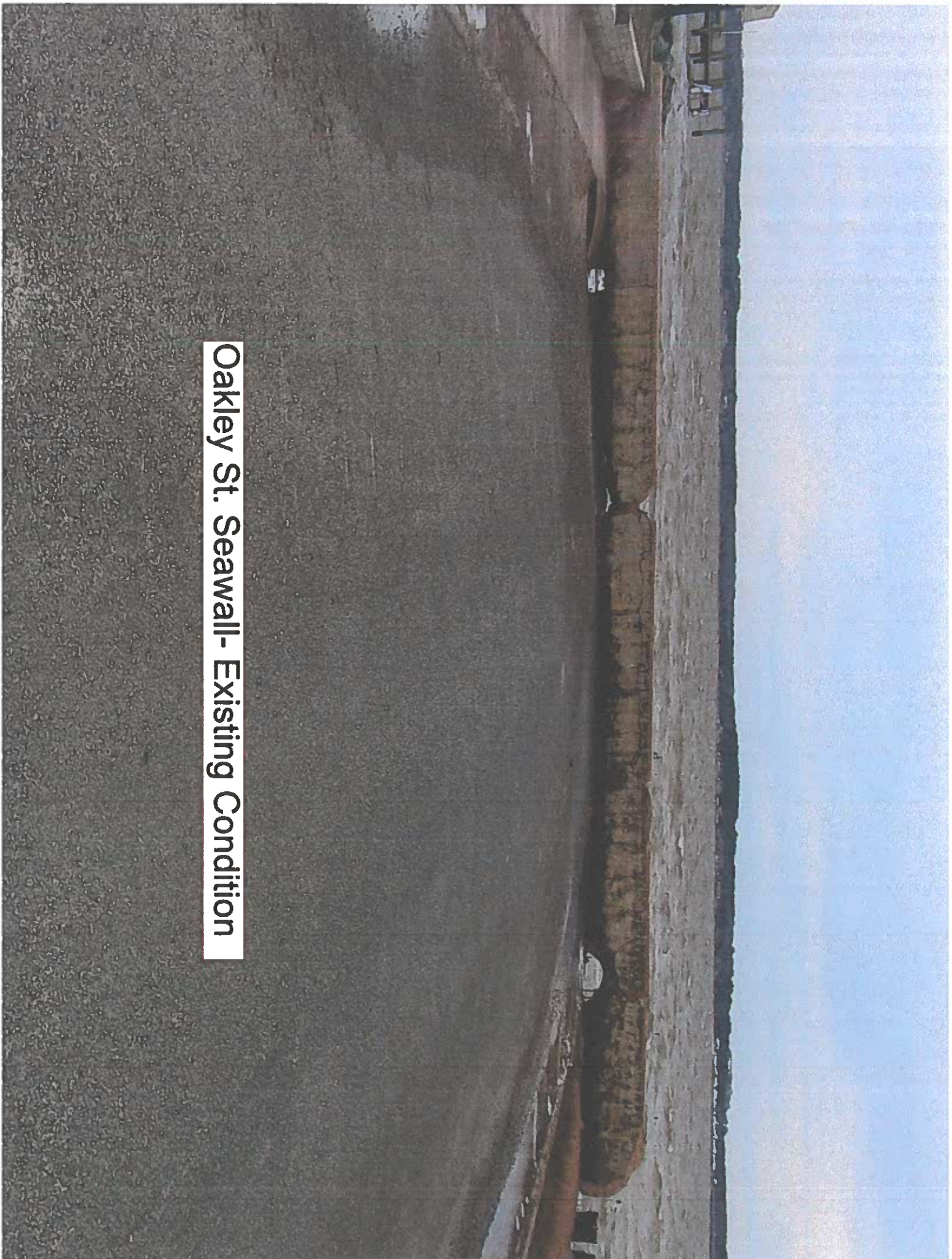

Oakley St. Seawall- Existing Condition

NOTES:

1. ALL CONSTRUCTION SHALL BE IN ACCORDANCE WITH THE CAMBRIDGE CITY ENGINEERING DEPARTMENT'S STANDARD SPECIFICATIONS FOR HIGHWAY CONSTRUCTION. THE CONTRACTOR SHALL BE RESPONSIBLE FOR OBTAINING ALL NECESSARY PERMITS AND APPROVALS FROM THE CITY ENGINEERING DEPARTMENT AND THE MASSACHUSETTS DEPARTMENT OF TRANSPORTATION. NECESSARY PRELIMINARY DESIGN SHALL BE COMPLETED AND APPROVED BY THE CITY ENGINEERING DEPARTMENT AND THE MASSACHUSETTS DEPARTMENT OF TRANSPORTATION BEFORE CONSTRUCTION BEGINS. ANY DAMAGE TO EXISTING UTILITIES SHALL BE REPAIRED IMMEDIATELY AT THE CONTRACTOR'S EXPENSE.
2. ALL UTILITIES TO BE REMOVED SHALL BE IDENTIFIED AND MARKED PRIOR TO CONSTRUCTION. THE CONTRACTOR SHALL BE RESPONSIBLE FOR OBTAINING ALL NECESSARY PERMITS AND APPROVALS FROM THE CITY ENGINEERING DEPARTMENT AND THE MASSACHUSETTS DEPARTMENT OF TRANSPORTATION. NECESSARY PRELIMINARY DESIGN SHALL BE COMPLETED AND APPROVED BY THE CITY ENGINEERING DEPARTMENT AND THE MASSACHUSETTS DEPARTMENT OF TRANSPORTATION BEFORE CONSTRUCTION BEGINS. ANY DAMAGE TO EXISTING UTILITIES SHALL BE REPAIRED IMMEDIATELY AT THE CONTRACTOR'S EXPENSE.
3. CONTRACTOR SHALL PROVIDE TEMPORARY SIDEWALKS AND RETAINING SYSTEMS TO MAINTAIN ACCESS TO ADJACENT PROPERTIES AND TO MAINTAIN THE CITY STANDARD FOR SIDEWALKS AND CURBS. ANY DAMAGE TO EXISTING SIDEWALKS AND CURBS SHALL BE REPAIRED IMMEDIATELY AT THE CONTRACTOR'S EXPENSE.
4. CONTRACTOR SHALL PROVIDE TEMPORARY SIDEWALKS AND RETAINING SYSTEMS TO MAINTAIN ACCESS TO ADJACENT PROPERTIES AND TO MAINTAIN THE CITY STANDARD FOR SIDEWALKS AND CURBS. ANY DAMAGE TO EXISTING SIDEWALKS AND CURBS SHALL BE REPAIRED IMMEDIATELY AT THE CONTRACTOR'S EXPENSE.
5. CONTRACTOR SHALL PROVIDE TEMPORARY SIDEWALKS AND RETAINING SYSTEMS TO MAINTAIN ACCESS TO ADJACENT PROPERTIES AND TO MAINTAIN THE CITY STANDARD FOR SIDEWALKS AND CURBS. ANY DAMAGE TO EXISTING SIDEWALKS AND CURBS SHALL BE REPAIRED IMMEDIATELY AT THE CONTRACTOR'S EXPENSE.
6. CONTRACTOR SHALL PROVIDE TEMPORARY SIDEWALKS AND RETAINING SYSTEMS TO MAINTAIN ACCESS TO ADJACENT PROPERTIES AND TO MAINTAIN THE CITY STANDARD FOR SIDEWALKS AND CURBS. ANY DAMAGE TO EXISTING SIDEWALKS AND CURBS SHALL BE REPAIRED IMMEDIATELY AT THE CONTRACTOR'S EXPENSE.

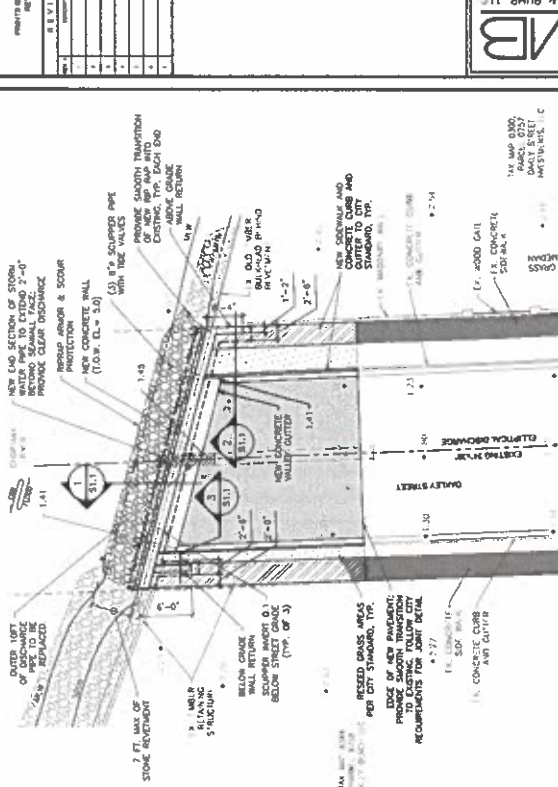
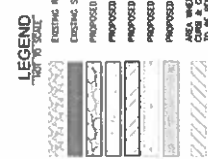

OAKLEY STREET EXISTING/DEMO PLAN
SCALE: 1" = 10'

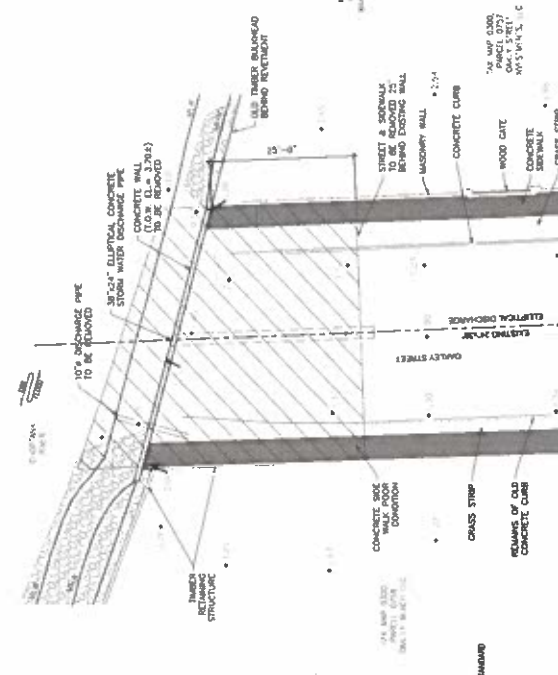

OAKLEY STREET IMPROVEMENT PLAN
SCALE: 1" = 10'

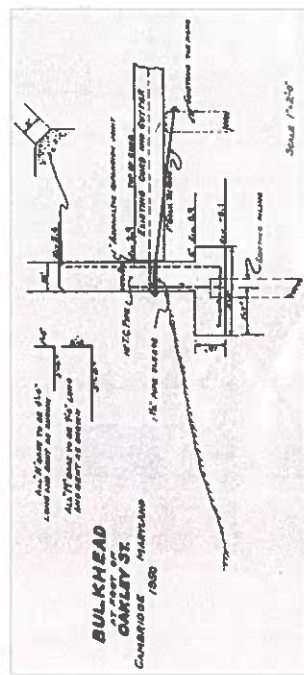
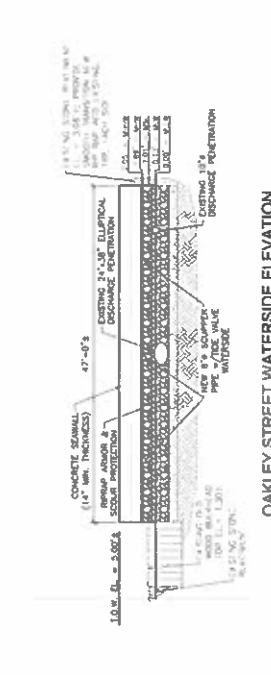
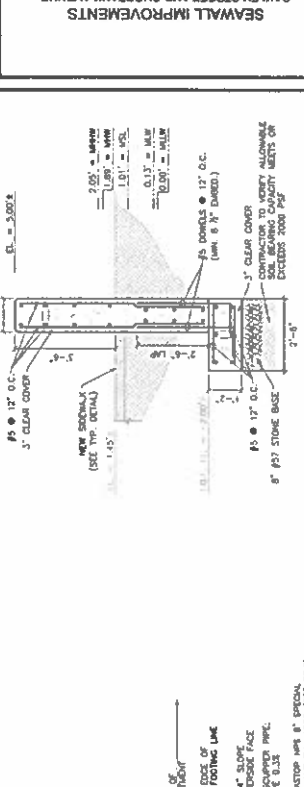

DIAGRAM OF POTENTIAL EXISTING CONDITIONS



OAKLEY STREET WATERSIDE ELEVATION
SCALE: 1/4" = 1'-0"



OAKLEY STREET PROPOSED SECTION 1
SCALE: 1/4" = 1'-0"

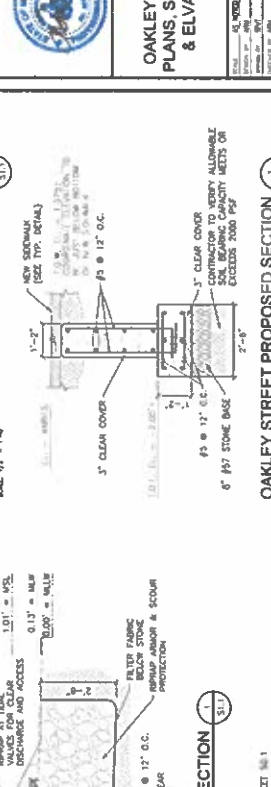

OAKLEY STREET PROPOSED SECTION 2
SCALE: 1/4" = 1'-0"

NO.	REVISION	DATE
1	ISSUED FOR PERMIT	08/15/2012
2	REVISED FOR REVIEW	08/15/2012
3	REVISED FOR REVIEW	08/15/2012
4	REVISED FOR REVIEW	08/15/2012
5	REVISED FOR REVIEW	08/15/2012
6	REVISED FOR REVIEW	08/15/2012
7	REVISED FOR REVIEW	08/15/2012
8	REVISED FOR REVIEW	08/15/2012
9	REVISED FOR REVIEW	08/15/2012
10	REVISED FOR REVIEW	08/15/2012

REVISIONS

OMB
GEORGE MILLS & ENGINEERS
ARCHITECTS & ENGINEERS
100 CONVENT ROAD
CAMBRIDGE, MASSACHUSETTS 02142
TELEPHONE: 617-552-1100
FAX: 617-552-1101
WWW.GEORGE-MILLS.COM

SEAWALL IMPROVEMENTS
OAKLEY STREET AND CHOPLANK AVENUE
CAMBRIDGE, MASSACHUSETTS



OAKLEY STREET PLANS, SECTIONS & ELEVATIONS

DATE: 08/15/2012
DRAWN BY: J. BROWN
CHECKED BY: J. BROWN
SCALE: AS SHOWN
SHEET NO: 1.1
TOTAL SHEETS: 1.1



1190 Winterson Road Suite 100
 Linthicum, MD 21090
 Phone: (410) 859-8600

Invoice # 358920	Page 1 of 1
Account Number COMMOFC-02	Date 5/5/2021
Balance Due On 5/18/2021	Transacted By CDUNN
Amount Paid	Amount Due \$1,687.00

Commissioners of Cambridge
 PO Box 255
 Cambridge, MD 21613

Remit Payment To:

United States Insurance Services
 1190 Winterson Road Suite 100
 Linthicum, MD 21090

Pollution	Policy Number: STEP011741	Effective: 5/18/2021 to 5/18/2022
-----------	---------------------------	-----------------------------------

Item #	Trans Eff Date	Due Date	Trans	Description	Amount
6505147	5/18/2021	5/18/2021	RENB	Renewal of POLL Effective 5/18/2021	\$1,537.00
6505148	5/18/2021	5/18/2021	STOT	Program Fee	\$150.00

Total Invoice Balance: \$1,687.00

RESOLUTION NO. 21-09

A RESOLUTION OF THE COMMISSIONERS OF CAMBRIDGE, MARYLAND TO AUTHORIZE THE APPLICATION FOR AND RECEIPT OF TECHNICAL ASSISTANCE GRANT (“TAG”) FUNDING IN THE AMOUNT OF \$35,000 TO ENGAGE A CONSULTANT TO FACILITATE THE CREATION OF A SMALL AREA PLAN FOR THE PINE STREET NEIGHBORHOOD (THE “PROJECT”), WITH SUCH FUNDING TO BE PROVIDED EITHER DIRECTLY BY THE STATE DEPARTMENT OF HOUSING AND COMMUNITY DEVELOPMENT (“DHCD”) OR THROUGH OTHER DEPARTMENTS OR AGENCIES OF THE STATE OF MARYLAND.

WHEREAS, the Commissioners of Cambridge recognize that there is a significant need for reinvestment and revitalization of the communities in the City of Cambridge; and

WHEREAS, in furtherance of the foregoing, the Commissioners of Cambridge endorse the creation of a small area plan for the Pine Street Neighborhood (i.e., the Project) to facilitate the redevelopment thereof; and

WHEREAS, the State of Maryland, through DHCD, has solicited applications from eligible jurisdictions to apply for funding under the Maryland Technical Assistance Grant program; and

WHEREAS, the City is eligible to apply for funds from the Maryland Technical Assistance Grant program through DHCD; and

WHEREAS, DHCD, either through Technical Assistance Grants or other DHCD programs, or in cooperation with other State departments or agencies, may provide some or all the funding for the Project (the “Project Funding”) to assist in making it financially feasible; and

WHEREAS, the Project is located within a priority funding area under Section 5-78-02 of the Smart Growth Act, and the Project will conform to all applicable local zoning codes, including, but not limited to, the Unified Development Code for the City of Cambridge (the “UDC”); and

WHEREAS, the applicable law and regulations require approval of the Project and the Project Funding by the Commissioners of Cambridge; and

WHEREAS, the Project will provide a material benefit to the City and its residents; and

WHEREAS, the Commissioners of Cambridge are desirous of approving the application for and receipt of the Project Funding, upon the terms and conditions set forth in this Resolution.

NOW, THEREFORE, BE IT RESOLVED BY THE COMMISSIONERS OF CAMBRIDGE that the Commissioners of Cambridge hereby endorse the Project and authorize the submittal of an application for and receipt of TAG funding for the Project in the amount of Thirty-Five Thousand Dollars (\$35,000).

AND BE IT FURTHER RESOLVED THAT the Mayor is hereby authorized and empowered to execute any and all documents required for the submission of the TAG application and take any action necessary to carry out the intent of this Resolution.

AND BE IT FURTHER RESOLVED THAT, upon adoption, copies of this Resolution shall be sent to DHCD.

AND BE IT FURTHER RESOLVED THAT, in executing this Resolution, the Mayor hereby certifies that this Resolution is true and correct and duly adopted by the Commissioners of Cambridge.

ATTEST: THE COMMISSIONERS OF CAMBRIDGE

Patrick C. Comiskey
City Manager

BY: _____
Andrew Bradshaw
Mayor

Adopted the 10th day of May, 2021
Effective the 10th day of May, 2021