



City of Cambridge

DEPARTMENT OF PUBLIC WORKS

PLANNING & ZONING

1025 WASHINGTON STREET
CAMBRIDGE, MARYLAND 21613
410-228-1955

Historic Preservation Commission Staff Report

June 16, 2021

I. BACKGROUND INFORMATION:

Applicant/Owner: Ms. Nanette Speer/Economy Restoration
HPC Case No.: HPC 2021-065
Nature of Request: Slate Roof Replacement
Location of Property: 112 Oakley
Total Acreage: 9,304 sf
Zoning: NC-2
Year Built: 1910

II. **BACKGROUND:** This is an application remove an existing slate roof and replace it with a synthetic slate roofing-material.

III. DISCUSSION: (National Register)



401. 112 Oakley Street (D-551). Two story, two bay foursquare with Colonial Revival style detailing. There is a pedimented front dormer with a Palladian window and a wraparound porch with a pedimented entrance bay. Ca. 1910. Contributing building. B.

Scope of Work:

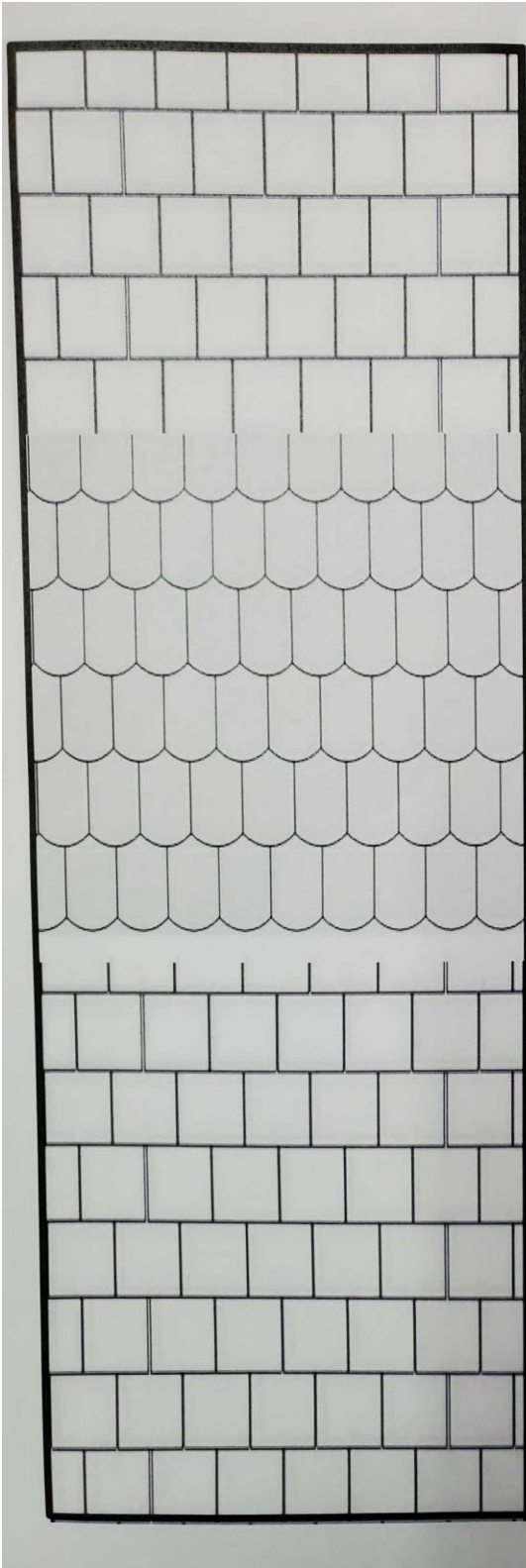

Section 1 Synthetic Slate Rear roof area

Roof Peak (pattern is symmetric on both sides of roof)

Number of rows and height of rectangular 9" wide slate

12

Number of rows and height of 8" beveled slate

16

Number of rows and height of rectangular 9" slate

16

Bottom of roof

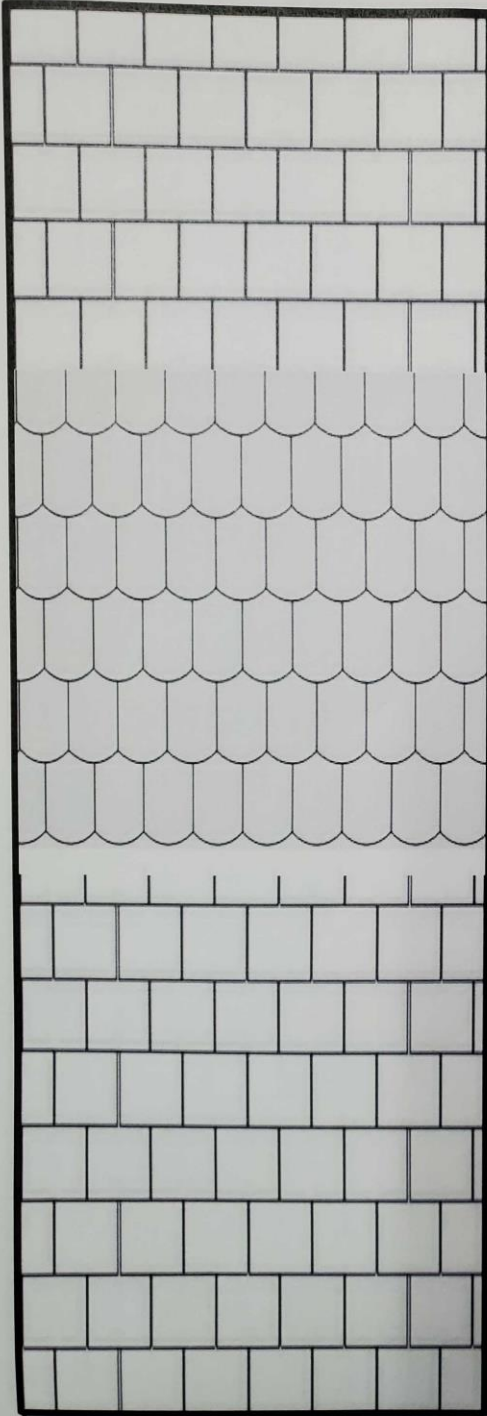

Section 2 Synthetic Slate Main roof

Roof Peak (pattern is symmetric on both sides of roof)

Number of rows and height of rectangular 9" wide slate

12

Number of rows and height of 8" beveled slate

16

Number of rows and height of rectangular 9" slate

16

Bottom of roof

Section 3 Synthetic Slate Dormers

Roof Peak (pattern is symmetric on both sides of roof)

Number of rows and height of rectangular 9" wide slate

0

Number of rows and height of 8" beveled slate

All

Number of rows and height of rectangular 9" slate

N/A

Bottom of roof

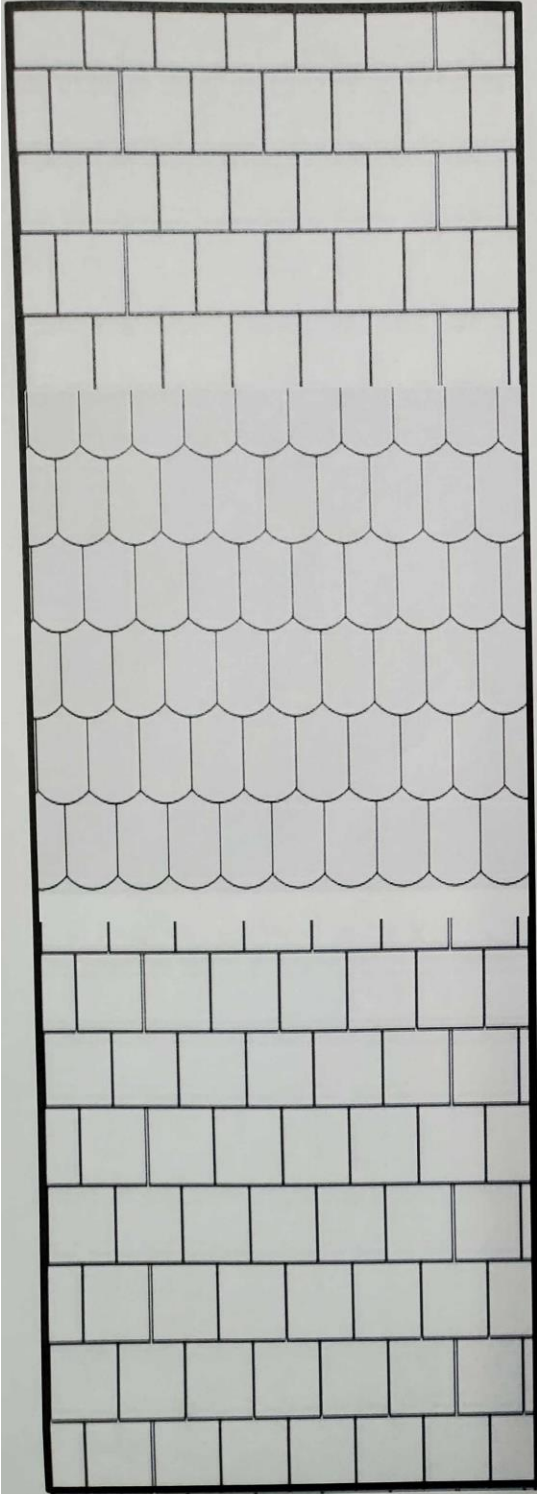

BUILDING DETAIL SHEET

- | | |
|--|--|
| <p>1. Footing Size _____</p> <p>2. Pier Footing Size _____</p> <p>3. Foundation Block Size _____</p> <p>4. Column/Pier Size _____</p> <p>5. Beam Size _____</p> <p>6. First Floor Joist Size _____</p> <p>6b. Length & Spacing _____</p> <p>7. Floor Sheathing/Material _____</p> <p>8. Wall Studs 2X _____ @ _____ Centers</p> <p>9. Ceiling Joist Size _____</p> | <p>9a. Length & Spacing _____</p> <p>10. Header Sizes _____</p> <p>11. Roof Rafters _____</p> <p>12. Length & Spacing _____</p> <p>13. Roof Sheathing <u>Plywood</u></p> <p>14. Roof Pitch & Style <u>8/12 12/12</u></p> <p>15. Insulation Value: Walls _____</p> <p>Floors _____ Ceiling _____</p> <p>16. Roof Material <u>ASPHALT</u></p> |
|--|--|

Review and approval of plans does not relieve the owner from building in accordance with ALL applicable sections of the Town of Centreville Building Code.

Plans Approved by _____

Owner/Applicant: _____

Permit must be Posted before any inspection will be performed.

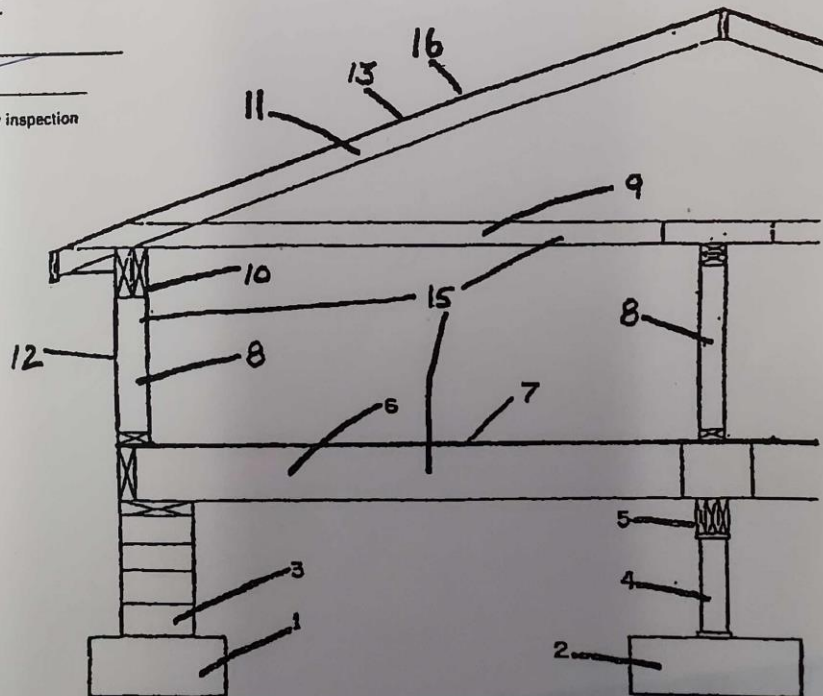

IV. Staff Recommendation:
Staff defers to HPC comments and review.